

# YGE235 SERIES

YL235P-29b  
YL230P-29b  
YL225P-29b

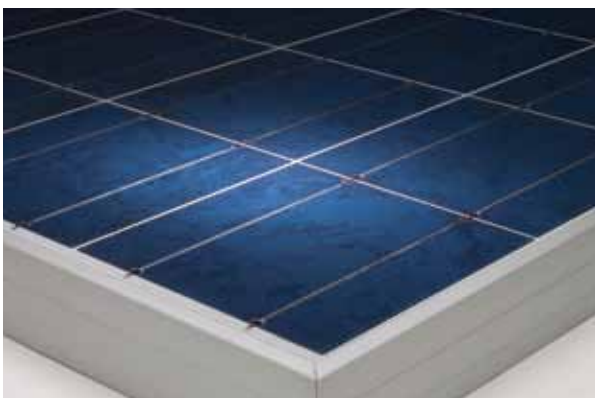

Official Sponsor of the 2010 FIFA World Cup™



## COMPANY

Yingli Green Energy (NYSE:YGE) is one of the world's largest fully vertically integrated PV manufacturers. With over 1 GW of modules installed globally, we are a leading solar energy company built upon proven product reliability and sustainable performance. Founded in 1998, Yingli Green Energy opened offices in New York and San Francisco in 2009. We are the first renewable energy company and the first Chinese company to sponsor the FIFA World Cup™.

## PERFORMANCE

- Industry leading in-house manufacturing of polysilicon, ingots, wafers, cells and modules ensures tight control of our material and production quality.
- High performance, multicrystalline solar cells deliver a module series efficiency of up to 14.4%, reducing installation costs and maximizing the kWh output per unit area.
- Power tolerance of +/-3% minimizes PV system mismatch losses.

## QUALITY & RELIABILITY

- Robust, corrosion resistant aluminum frame independently tested to withstand wind and snow loads of up to 50 psf and 113 psf, respectively, ensuring a stable mechanical life.
- Manufacturing facility certified to ISO9001 Quality Management System standards.
- Module packaging optimized to protect product during transportation and minimize on-site waste.

## WARRANTIES

- Extensive 5-year limited product warranty and a 25-year limited power warranty.
- Limited power warranty\* = 90% of the minimum rated power output for 10 years, 80% of the minimum rated power output for 25 years.

\* In compliance with our warranty terms and conditions.

## QUALIFICATIONS & CERTIFICATES

UL 1703 and ULC 1703, UL Fire Safety Class C, CEC, FSEC  
ISO 9001:2008, ISO 14001:2004, BS OSHAS 18001:2007, SA8000



# YGE235 SERIES

## ELECTRICAL PERFORMANCE

Electrical parameters at Standard Test Conditions (STC)					
Module name			YGE 235	YGE 230	YGE 225
Module type			YL235P-29b	YL230P-29b	YL225P-23b
Power output	$P_{max}$	W	235	230	225
Power output tolerances	$\Delta P_{max}$	%	+/- 3		
Module efficiency	$\eta_m$	%	14.4	14.1	13.8
Voltage at $P_{max}$	$V_{mpp}$	V	29.5	29.5	29.5
Current at $P_{max}$	$I_{mpp}$	A	7.97	7.80	7.63
Open-circuit voltage	$V_{oc}$	V	37.0	37.0	36.5
Short-circuit current	$I_{sc}$	A	8.54	8.40	8.28

STC: 1000W/m<sup>2</sup> irradiance, 25°C T<sub>module</sub>, AM1.5g spectrum according to EN 60904-3  
Ave. efficiency reduction of 2% at 200W/m<sup>2</sup> according to EN 60904-1

Electrical parameters at Nominal Operating Cell Temperature (NOCT)					
Power output	$P_{max}$	W	169.9	166.4	162.7
Voltage at $P_{max}$	$V_{mpp}$	V	26.5	26.5	26.5
Current at $P_{max}$	$I_{mpp}$	A	6.41	6.28	6.14
Open-circuit voltage	$V_{oc}$	V	33.8	33.8	33.4
Short-circuit current	$I_{sc}$	A	6.92	6.8	6.71

NOCT: open-circuit module operation temperature at 800W/m<sup>2</sup> irradiance, 20°C T<sub>ambient</sub>, 1 m/s wind speed

## THERMAL CHARACTERISTICS

Nominal operating cell temperature	NOCT	°C	46 +/- 2
Temperature coefficient of $P_{max}$	$\gamma$	%/°C	-0.45
Temperature coefficient of $V_{oc}$	$\beta_{Voc}$	%/°C	-0.37
Temperature coefficient of $I_{sc}$	$\alpha_{Isc}$	%/°C	0.06

## OPERATING CONDITIONS

Max. system voltage	600V <sub>dc</sub>
Max. series fuse rating	15A
Limiting reverse current	Do not apply external voltages larger than $V_{oc}$ of the module
Operating temperature range	-40 to 194°F (-40 to 90°C)
Max. static load, front (e.g., snow and wind)	113 psf (5400 Pa)
Max. static load, back (e.g., wind)	50 psf (2400 Pa)
Hailstone impact	1 in (25mm) at 51 mph (23m/s)

## CONSTRUCTION MATERIALS

Units: inch (mm)	
Front cover (material/type/thickness)	low-iron glass/tempered/3.2mm
Cell (quantity/material/type/dimensions/area)	60/polysilicon/multicrystalline/156x156mm/243.3cm <sup>2</sup>
Encapsulant (material)	ethylene vinyl acetate (EVA)
Frame (material/color/anodization color)	anodized aluminum alloy/silver/clear
Junction box (protection degree)	IP65
Cable (length/cross-sectional area)	47.24 (1200)/12 AWG
Plug connector (manufacturer/type/protection degree)	MC/MC4/IP67

- The specifications in this datasheet are not guaranteed and are subject to change without prior notice.
- This datasheet complies with EN 50380:2003 requirements.

## Yingli Green Energy Americas, Inc.

us-info@yinglisolar.com

Tel: +1 (888) 686-8820

**YINGLISOLAR.COM**

## GENERAL CHARACTERISTICS

Units: inch (mm)	
Dimensions (length/width/height)	64.96 (1650)/38.98 (990)/1.97 (50)
Weight	43.7 lbs (19.8 kg)

## PACKAGING SPECIFICATIONS

Units: inch (mm)	
Number of modules per pallet	20
Number of pallets per 53' container	36
Packaging box dimensions (L/W/H)	67 (1710)/45 (1150)/47 (1190)
Box weight	992 lbs (450 kg)

Units: inch (mm)

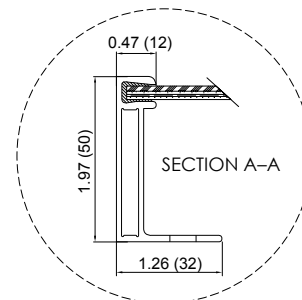
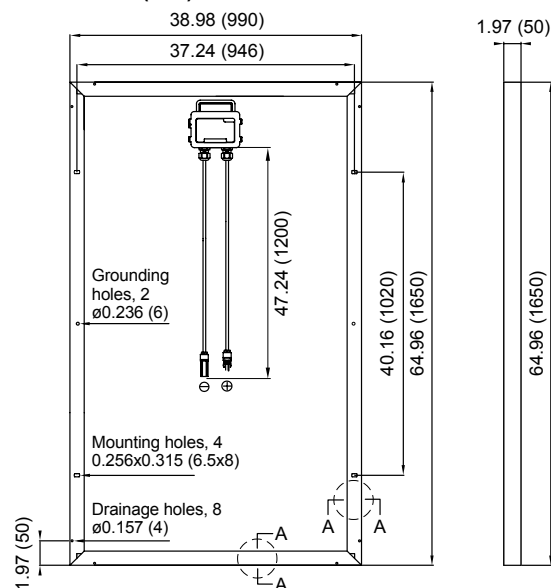

Warning: Read the instruction manual in its entirety before handling, installing, and operating Yingli modules.

